



**PDHonline Course E243 (3 PDH)**

---

# **Electrical Fundamentals – Overview of Transformers**

*Instructor: A. Bhatia, B.E.*

**2020**

**PDH Online | PDH Center**

5272 Meadow Estates Drive  
Fairfax, VA 22030-6658  
Phone: 703-988-0088  
[www.PDHonline.com](http://www.PDHonline.com)

An Approved Continuing Education Provider

# CHAPTER 5

## TRANSFORMERS

### LEARNING OBJECTIVES

Upon completion of this chapter you will be able to:

1. State the meaning of "transformer action."
2. State the physical characteristics of a transformer, including the basic parts, common core materials, and main core types.
3. State the names given to the source and load windings of a transformer.
4. State the difference in construction between a high- and a low-voltage transformer.
5. Identify transformer symbols as to the type of transformer each symbol represents and the method used to denote transformer phasing.
6. State the meaning of a "no-load condition" and "exciting current" relative to a transformer.
7. State what causes voltage to be developed across the secondary of a transformer and the effect of cemf in a transformer.
8. State the meaning of leakage flux and its effect on the coefficient of coupling.
9. Identify a transformer as step up or step down and state the current ratio of a transformer when given the turns ratio.
10. Solve for primary voltage, secondary voltage, primary current and number of turns in the secondary given various transformer values.
11. State the mathematical relationship between the power in the primary and the power in the secondary of a transformer and compute efficiency of a transformer.
12. State the three power losses in a transformer.
13. State the reason a transformer should not be operated at a lower frequency than that specified for the transformer.
14. List five different types of transformers according to their applications.
15. State the standard color coding for a power transformer.
16. State the general safety precautions you should observe when working with transformers and other electrical components.

## TRANSFORMERS

The information in this chapter is on the construction, theory, operation, and the various uses of transformers. Safety precautions to be observed by a person working with transformers are also discussed.

A TRANSFORMER is a device that transfers electrical energy from one circuit to another by electromagnetic induction (transformer action). The electrical energy is always transferred without a change in frequency, but may involve changes in magnitudes of voltage and current. Because a transformer works on the principle of electromagnetic induction, it must be used with an input source voltage that varies in amplitude. There are many types of power that fit this description; for ease of explanation and understanding, transformer action will be explained using an ac voltage as the input source.

In a preceding chapter you learned that alternating current has certain advantages over direct current. One important advantage is that when ac is used, the voltage and current levels can be increased or decreased by means of a transformer.

As you know, the amount of power used by the load of an electrical circuit is equal to the current in the load times the voltage across the load, or  $P = EI$ . If, for example, the load in an electrical circuit requires an input of 2 amperes at 10 volts (20 watts) and the source is capable of delivering only 1 ampere at 20 volts, the circuit could not normally be used with this particular source. However, if a transformer is connected between the source and the load, the voltage can be decreased (stepped down) to 10 volts and the current increased (stepped up) to 2 amperes. Notice in the above case that the power remains the same. That is, 20 volts times 1 ampere equals the same power as 10 volts times 2 amperes.

*Q1. What is meant by "transformer action?"*

### BASIC OPERATION OF A TRANSFORMER

In its most basic form a transformer consists of:

- A primary coil or winding.
- A secondary coil or winding.
- A core that supports the coils or windings.

Refer to the transformer circuit in figure 5-1 as you read the following explanation: The primary winding is connected to a 60 hertz ac voltage source. The magnetic field (flux) builds up (expands) and collapses (contracts) about the primary winding. The expanding and contracting magnetic field around the primary winding cuts the secondary winding and induces an alternating voltage into the winding. This voltage causes alternating current to flow through the load. The voltage may be stepped up or down depending on the design of the primary and secondary windings.

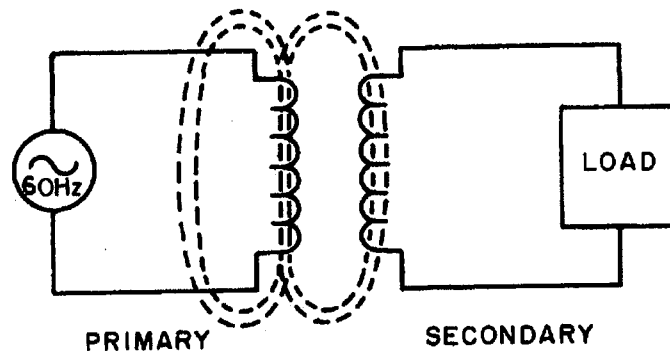

Figure 5-1.—Basic transformer action.

Q2. What are, the three basic parts of a transformer?

### THE COMPONENTS OF A TRANSFORMER

Two coils of wire (called windings) are wound on some type of core material. In some cases the coils of wire are wound on a cylindrical or rectangular cardboard form. In effect, the core material is air and the transformer is called an AIR-CORE TRANSFORMER. Transformers used at low frequencies, such as 60 hertz and 400 hertz, require a core of low-reluctance magnetic material, usually iron. This type of transformer is called an IRON-CORE TRANSFORMER. Most power transformers are of the iron-core type. The principle parts of a transformer and their functions are:

- The CORE, which provides a path for the magnetic lines of flux.
- The PRIMARY WINDING, which receives energy from the ac source.
- The SECONDARY WINDING, which receives energy from the primary winding and delivers it to the load.
- The ENCLOSURE, which protects the above components from dirt, moisture, and mechanical damage.

### CORE CHARACTERISTICS

The composition of a transformer core depends on such factors as voltage, current, and frequency. Size limitations and construction costs are also factors to be considered. Commonly used core materials are air, soft iron, and steel. Each of these materials is suitable for particular applications and unsuitable for others. Generally, air-core transformers are used when the voltage source has a high frequency (above 20 kHz). Iron-core transformers are usually used when the source frequency is low (below 20 kHz). A soft-iron-core transformer is very useful where the transformer must be physically small, yet efficient. The iron-core transformer provides better power transfer than does the air-core transformer. A transformer whose core is constructed of laminated sheets of steel dissipates heat readily; thus it provides for the efficient transfer of power. The majority of transformers you will encounter in Navy equipment contain laminated-steel cores. These steel laminations (see figure 5-2) are insulated with a nonconducting material, such as varnish, and then formed into a core. It takes about 50 such laminations to make a core an inch thick. The purpose of the laminations is to reduce certain losses which will be discussed later in this chapter. An important point to

remember is that the most efficient transformer core is one that offers the best path for the most lines of flux with the least loss in magnetic and electrical energy.

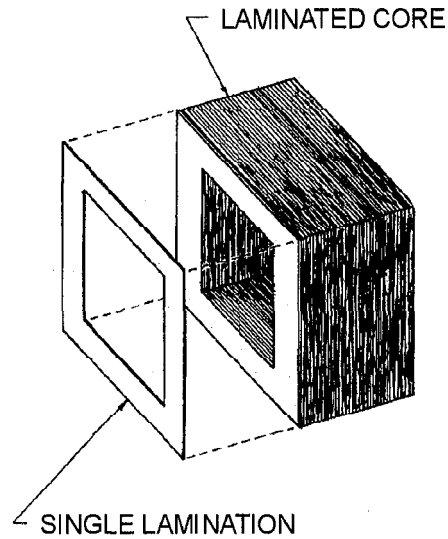

Figure 5-2.—Hollow-core construction.

Q3. What are three materials commonly used as the core of a transformer?

### Hollow-Core Transformers

There are two main shapes of cores used in laminated-steel-core transformers. One is the HOLLOW-CORE, so named because the core is shaped with a hollow square through the center. Figure 5-2 illustrates this shape of core. Notice that the core is made up of many laminations of steel. Figure 5-3 illustrates how the transformer windings are wrapped around both sides of the core.

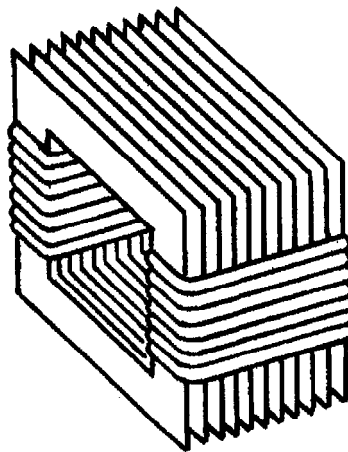

Figure 5-3.—Windings wrapped around laminations.

## Shell-Core Transformers

The most popular and efficient transformer core is the SHELL CORE, as illustrated in figure 5-4. As shown, each layer of the core consists of E- and I-shaped sections of metal. These sections are butted together to form the laminations. The laminations are insulated from each other and then pressed together to form the core.

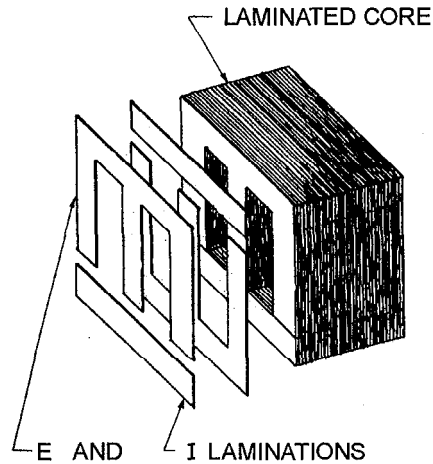

Figure 5-4.—Shell-type core construction.

*Q4. What are the two main types of cores used in transformers?*

## TRANSFORMER WINDINGS

As stated above, the transformer consists of two coils called WINDINGS which are wrapped around a core. The transformer operates when a source of ac voltage is connected to one of the windings and a load device is connected to the other. The winding that is connected to the source is called the PRIMARY WINDING. The winding that is connected to the load is called the SECONDARY WINDING. (Note: In this chapter the terms "primary winding" and "primary" are used interchangeably; the term: "secondary winding" and "secondary" are also used interchangeably.)

Figure 5-5 shows an exploded view of a shell-type transformer. The primary is wound in layers directly on a rectangular cardboard form.

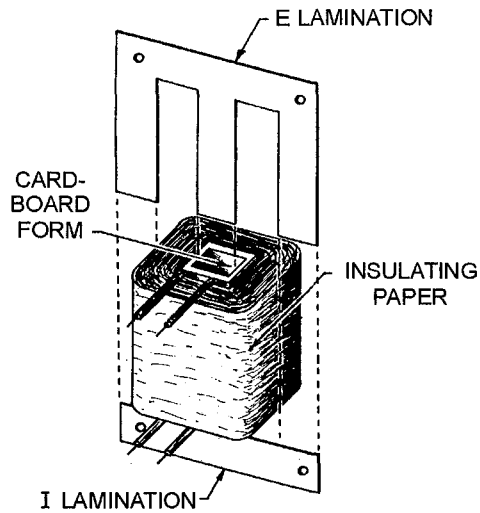

Figure 5-5.—Exploded view of shell-type transformer construction.

In the transformer shown in the cutaway view in figure 5-6, the primary consists of many turns of relatively small wire. The wire is coated with varnish so that each turn of the winding is insulated from every other turn. In a transformer designed for high-voltage applications, sheets of insulating material, such as paper, are placed between the layers of windings to provide additional insulation.

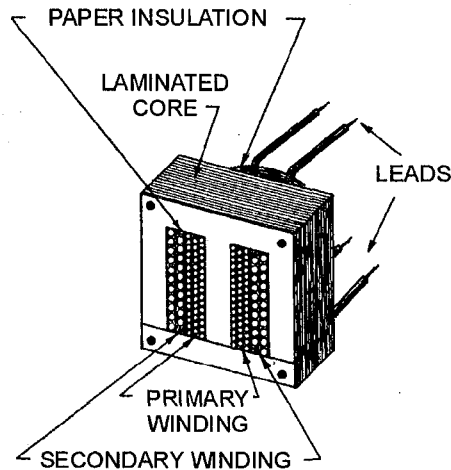

Figure 5-6.—Cutaway view of shell-type core with windings.

When the primary winding is completely wound, it is wrapped in insulating paper or cloth. The secondary winding is then wound on top of the primary winding. After the secondary winding is complete, it too is covered with insulating paper. Next, the E and I sections of the iron core are inserted into and around the windings as shown.

The leads from the windings are normally brought out through a hole in the enclosure of the transformer. Sometimes, terminals may be provided on the enclosure for connections to the windings. The figure shows four leads, two from the primary and two from the secondary. These leads are to be connected to the source and load, respectively.

- Q5. Which transformer windings are connected to an ac source voltage and to a load, respectively?
- Q6. A transformer designed for high-voltage applications differs in construction in what way from a transformer designed for low-voltage applications?

### SCHEMATIC SYMBOLS FOR TRANSFORMERS

Figure 5-7 shows typical schematic symbols for transformers. The symbol for an air-core transformer is shown in figure 5-7(A). Parts (B) and (C) show iron-core transformers. The bars between the coils are used to indicate an iron core. Frequently, additional connections are made to the transformer windings at points other than the ends of the windings. These additional connections are called TAPS. When a tap is connected to the center of the winding, it is called a CENTER TAP. Figure 5-7(C) shows the schematic representation of a center-tapped iron-core transformer.

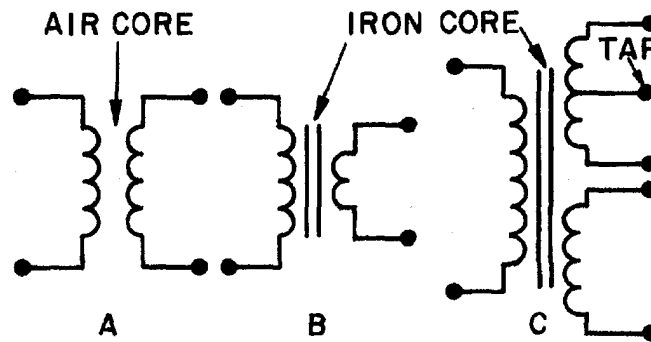
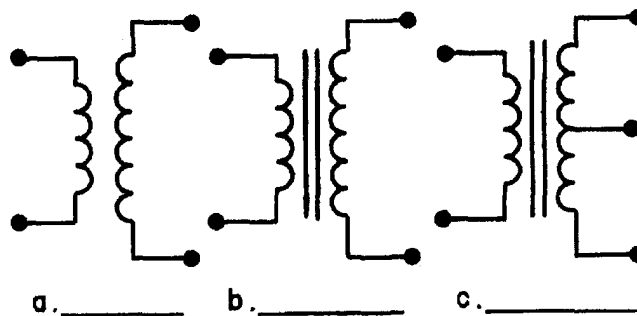

Figure 5-7.—Schematic symbols for various types of transformers.

- Q7. Identify the below schematic symbols of transformers by labeling them in the blanks provided.





## HOW A TRANSFORMER WORKS

Up to this point the chapter has presented the basics of the transformer including transformer action, the transformer's physical characteristics, and how the transformer is constructed. Now you have the necessary knowledge to proceed into the theory of operation of a transformer.

### NO-LOAD CONDITION

You have learned that a transformer is capable of supplying voltages which are usually higher or lower than the source voltage. This is accomplished through mutual induction, which takes place when the changing magnetic field produced by the primary voltage cuts the secondary winding.

A no-load condition is said to exist when a voltage is applied to the primary, but no load is connected to the secondary, as illustrated by figure 5-8. Because of the open switch, there is no current flowing in the secondary winding. With the switch open and an ac voltage applied to the primary, there is, however, a very small amount of current called **EXCITING CURRENT** flowing in the primary. Essentially, what the exciting current does is "excite" the coil of the primary to create a magnetic field. The amount of exciting current is determined by three factors: (1) the amount of voltage applied ( $E_a$ ), (2) the resistance ( $R$ ) of the primary coil's wire and core losses, and (3) the  $X_L$  which is dependent on the frequency of the exciting current. These last two factors are controlled by transformer design.

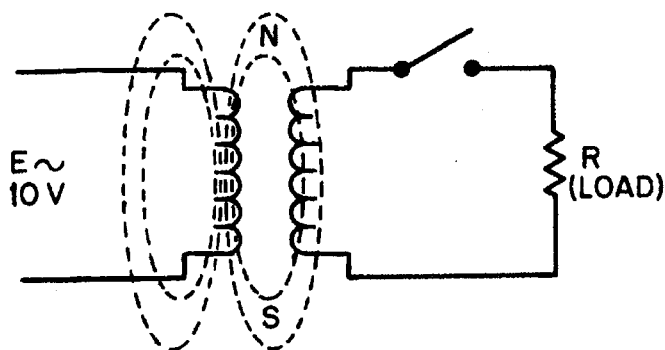

Figure 5-8.—Transformer under no-load conditions.

This very small amount of exciting current serves two functions:

1. Most of the exciting energy is used to maintain the magnetic field of the primary.
2. A small amount of energy is used to overcome the resistance of the wire and core losses which are dissipated in the form of heat (power loss).

Exciting current will flow in the primary winding at all times to maintain this magnetic field, but no transfer of energy will take place as long as the secondary circuit is open.

*Q8. What is meant by a "no-load condition" in a transformer circuit?*

### PRODUCING A COUNTER EMF

When an alternating current flows through a primary winding, a magnetic field is established around the winding. As the lines of flux expand outward, relative motion is present, and a counter emf is induced in the winding. This is the same counter emf that you learned about in the chapter on inductors. Flux leaves the primary at the north pole and enters the primary at the south pole. The counter emf induced in

the primary has a polarity that opposes the applied voltage, thus opposing the flow of current in the primary. It is the counter emf that limits exciting current to a very low value.

*Q9. What is meant by "exciting current" in a transformer?*

### **INDUCING A VOLTAGE IN THE SECONDARY**

To visualize how a voltage is induced into the secondary winding of a transformer, again refer to figure 5-8. As the exciting current flows through the primary, magnetic lines of force are generated. During the time current is increasing in the primary, magnetic lines of force expand outward from the primary and cut the secondary. As you remember, a voltage is induced into a coil when magnetic lines cut across it. Therefore, the voltage across the primary causes a voltage to be induced across the secondary.

*Q10. What is the name of the emf generated in the primary that opposes the flow of current in the primary?*

*Q11. What causes a voltage to be developed across the secondary winding of a transformer?*

### **PRIMARY AND SECONDARY PHASE RELATIONSHIP**

The secondary voltage of a simple transformer may be either in phase or out of phase with the primary voltage. This depends on the direction in which the windings are wound and the arrangement of the connections to the external circuit (load). Simply, this means that the two voltages may rise and fall together or one may rise while the other is falling.

Transformers in which the secondary voltage is in phase with the primary are referred to as LIKE-WOUND transformers, while those in which the voltages are 180 degrees out of phase are called UNLIKE-WOUND transformers.

Dots are used to indicate points on a transformer schematic symbol that have the same instantaneous polarity (points that are in phase).

The use of phase-indicating dots is illustrated in figure 5-9. In part (A) of the figure, both the primary and secondary windings are wound from top to bottom in a clockwise direction, as viewed from above the windings. When constructed in this manner, the top lead of the primary and the top lead of the secondary have the SAME polarity. This is indicated by the dots on the transformer symbol. A lack of phasing dots indicates a reversal of polarity.

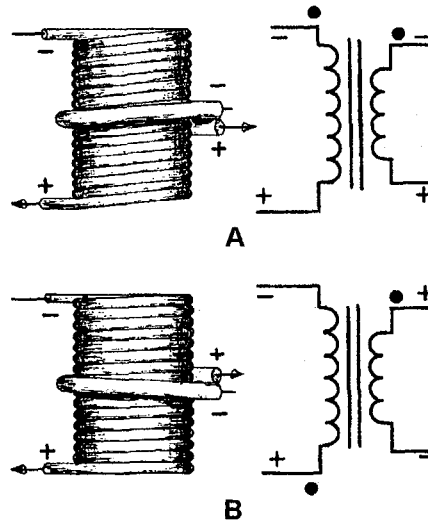
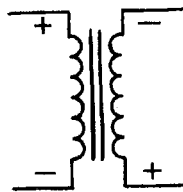

Figure 5-9.—Instantaneous polarity depends on direction of winding.

Part (B) of the figure illustrates a transformer in which the primary and secondary are wound in opposite directions. As viewed from above the windings, the primary is wound in a clockwise direction from top to bottom, while the secondary is wound in a counterclockwise direction. Notice that the top leads of the primary and secondary have OPPOSITE polarities. This is indicated by the dots being placed on opposite ends of the transformer symbol. Thus, the polarity of the voltage at the terminals of the secondary of a transformer depends on the direction in which the secondary is wound with respect to the primary.

*Q12. What is the phase relationship between the voltage induced in the secondary of an unlike-wound transformer and the counter emf of the primary winding?*

*Q13. Draw dots on the below symbol to indicate the phasing of the transformer.*



## COEFFICIENT OF COUPLING

The COEFFICIENT OF COUPLING of a transformer is dependent on the portion of the total flux lines that cuts both primary and secondary windings. Ideally, all the flux lines generated by the primary should cut the secondary, and all the lines of the flux generated by the secondary should cut the primary. The coefficient of coupling would then be one (unity), and maximum energy would be transferred from the primary to the secondary. Practical power transformers use high-permeability silicon steel cores and close spacing between the windings to provide a high coefficient of coupling.

Lines of flux generated by one winding which do not link with the other winding are called LEAKAGE FLUX. Since leakage flux generated by the primary does not cut the secondary, it cannot induce a voltage into the secondary. The voltage induced into the secondary is therefore less than it would be if the leakage flux did not exist. Since the effect of leakage flux is to lower the voltage induced into the

secondary, the effect can be duplicated by assuming an inductor to be connected in series with the primary. This series LEAKAGE INDUCTANCE is assumed to drop part of the applied voltage, leaving less voltage across the primary.

Q14. What is "leakage flux?"

Q15. What effect does flux leakage in a transformer have on the coefficient of coupling ( $K$ ) in the transformer?

## URNS AND VOLTAGE RATIOS

The total voltage induced into the secondary winding of a transformer is determined mainly by the RATIO of the number of turns in the primary to the number of turns in the secondary, and by the amount of voltage applied to the primary. Refer to figure 5-10. Part (A) of the figure shows a transformer whose primary consists of ten turns of wire and whose secondary consists of a single turn of wire. You know that as lines of flux generated by the primary expand and collapse, they cut BOTH the ten turns of the primary and the single turn of the secondary. Since the length of the wire in the secondary is approximately the same as the length of the wire in each turn in the primary, EMF INDUCED INTO THE SECONDARY WILL BE THE SAME AS THE EMF INDUCED INTO EACH TURN IN THE PRIMARY. This means that if the voltage applied to the primary winding is 10 volts, the counter emf in the primary is almost 10 volts. Thus, each turn in the primary will have an induced counter emf of approximately one-tenth of the total applied voltage, or one volt. Since the same flux lines cut the turns in both the secondary and the primary, each turn will have an emf of one volt induced into it. The transformer in part (A) of figure 5-10 has only one turn in the secondary, thus, the emf across the secondary is one volt.

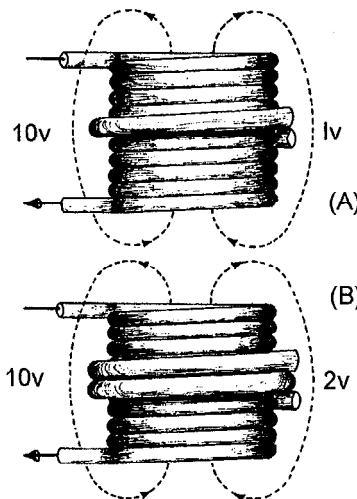

Figure 5-10.—Transformer turns and voltage ratios.

The transformer represented in part (B) of figure 5-10 has a ten-turn primary and a two-turn secondary. Since the flux induces one volt per turn, the total voltage across the secondary is two volts. Notice that the volts per turn are the same for both primary and secondary windings. Since the counter emf in the primary is equal (or almost) to the applied voltage, a proportion may be set up to express the value of the voltage induced in terms of the voltage applied to the primary and the number of turns in each winding. This proportion also shows the relationship between the number of turns in each winding and the voltage across each winding. This proportion is expressed by the equation:

$$\frac{E_s}{E_p} = \frac{N_s}{N_p}$$

Where:

$N_p$  = number of turns in the primary

$E_p$  = voltage applied to the primary

$E_s$  = voltage induced in the secondary

$N_s$  = number of turns in the secondary

Notice the equation shows that the ratio of secondary voltage to primary voltage is equal to the ratio of secondary turns to primary turns. The equation can be written as:

$$E_p N_s = E_s N_p$$

The following formulas are derived from the above equation:

$$\text{Transposing for } E_s: \quad E_s = \frac{E_p N_s}{N_p}$$

$$\text{Transposing for } E_p: \quad E_p = \frac{E_s N_p}{N_s}$$

If any three of the quantities in the above formulas are known, the fourth quantity can be calculated. Example. A transformer has 200 turns in the primary, 50 turns in the secondary, and 120 volts applied to the primary ( $E_p$ ). What is the voltage across the secondary ( $E_s$ )?

Given:  $N_p = 200$  turns  
 $N_s = 50$  turns  
 $E_p = 120$  volts  
 $E_s = ?$  volts

$$\text{Solution:} \quad E_s = \frac{E_p N_s}{N_p}$$

$$\text{Substitution:} \quad E_s = \frac{120 \text{ volts} \times 50 \text{ turns}}{200 \text{ turns}}$$

$$E_s = 30 \text{ volts}$$

Example. There are 400 turns of wire in an iron-core coil. If this coil is to be used as the primary of a transformer, how many turns must be wound on the coil to form the secondary winding of the transformer to have a secondary voltage of one volt if the primary voltage is five volts?

Given:

$$N_P = 400 \text{ turns}$$

$$E_P = 5 \text{ volts}$$

$$E_S = 1 \text{ volt}$$

$$N_S = ? \text{ turns}$$

Solution:

$$E_P N_S = E_S N_P$$

Transposing for  $N_S$ :

$$N_S = \frac{E_S N_P}{E_P}$$

Substitution:

$$N_S = \frac{1 \text{ volt} \times 400 \text{ turns}}{5 \text{ volts}}$$

$$N_S = 80 \text{ turns}$$

Note: The ratio of the voltage (5:1) is equal to the turns ratio (400:80). Sometimes, instead of specific values, you are given a turns or voltage ratio. In this case, you may assume any value for one of the voltages (or turns) and compute the other value from the ratio. For example, if a turn ratio is given as 6:1, you can assume a number of turns for the primary and compute the secondary number of turns (60:10, 36:6, 30:5, etc.).

The transformer in each of the above problems has fewer turns in the secondary than in the primary. As a result, there is less voltage across the secondary than across the primary. A transformer in which the voltage across the secondary is less than the voltage across the primary is called a STEP-DOWN transformer. The ratio of a four-to-one step-down transformer is written as 4:1. A transformer that has fewer turns in the primary than in the secondary will produce a greater voltage across the secondary than the voltage applied to the primary. A transformer in which the voltage across the secondary is greater than the voltage applied to the primary is called a STEP-UP transformer. The ratio of a one-to-four step-up transformer should be written as 1:4. Notice in the two ratios that the value of the primary winding is always stated first.

*Q16. Does 1:5 indicate a step-up or step-down transformer?*

*Q17. A transformer has 500 turns on the primary and 1500 turns on the secondary. If 45 volts are applied to the primary, what is the voltage developed across the secondary? (Assume no losses)*

*Q18. A transformer has a turns ratio of 7:1. If 5 volts is developed across the secondary, what is the voltage applied to the primary? (Note:  $E_S$  is given, what is  $E_P$ ?)*

*Q19. A transformer has 60 volts applied to its primary and 420 volts appearing across its secondary. If there are 800 turns on the primary, what is the number of turns in the secondary?*

## EFFECT OF A LOAD

When a load device is connected across the secondary winding of a transformer, current flows through the secondary and the load. The magnetic field produced by the current in the secondary interacts with the magnetic field produced by the current in the primary. This interaction results from the mutual inductance between the primary and secondary windings.

## MUTUAL FLUX

The total flux in the core of the transformer is common to both the primary and secondary windings. It is also the means by which energy is transferred from the primary winding to the secondary winding. Since this flux links both windings, it is called **MUTUAL FLUX**. The inductance which produces this flux is also common to both windings and is called mutual inductance.

Figure 5-11 shows the flux produced by the currents in the primary and secondary windings of a transformer when source current is flowing in the primary winding.

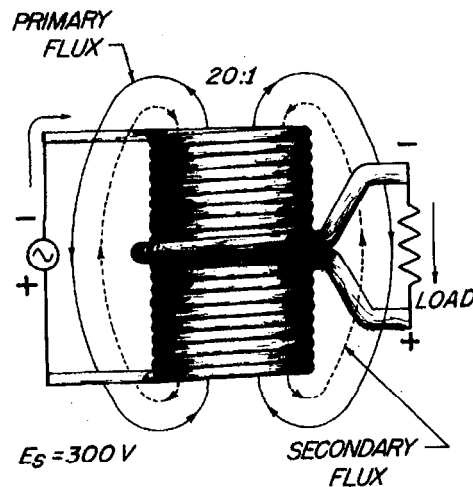

Figure 5-11.—Simple transformer indicating primary- and secondary-winding flux relationship.

When a load resistance is connected to the secondary winding, the voltage induced into the secondary winding causes current to flow in the secondary winding. This current produces a flux field about the secondary (shown as broken lines) which is in opposition to the flux field about the primary (Lenz's law). Thus, the flux about the secondary cancels some of the flux about the primary. With less flux surrounding the primary, the counter emf is reduced and more current is drawn from the source. The additional current in the primary generates more lines of flux, nearly reestablishing the original number of total flux lines.

## TURNS AND CURRENT RATIOS

The number of flux lines developed in a core is proportional to the magnetizing force (IN AMPERE-TURNS) of the primary and secondary windings. The ampere-turn ( $I \times N$ ) is a measure of magnetomotive force; it is defined as the magnetomotive force developed by one ampere of current flowing in a coil of one turn. The flux which exists in the core of a transformer surrounds both the primary and secondary windings. Since the flux is the same for both windings, the ampere-turns in both the primary and secondary windings must be the same.

Therefore:

$$I_P N_P = I_S N_S$$

Where:

$I_P N_P$  = amper e - turns in the primary winding

$I_S N_S$  = amper e - turns in the secondary winding

By dividing both sides of the equation by  $I_P N_S$ , you obtain:

$$\frac{N_P}{N_S} = \frac{I_S}{I_P}$$

Since:  $\frac{E_S}{E_P} = \frac{N_S}{N_P}$

Then:  $\frac{E_P}{E_S} = \frac{N_P}{N_S}$

And:  $\frac{E_P}{E_S} = \frac{I_S}{I_P}$

Where:

$E_P$  = voltage applied to the primary in volts

$E_S$  = voltage across the secondary in volts

$I_P$  = current in the primary in amper es

$I_S$  = current in the secondary in amper es

Notice the equations show the current ratio to be the inverse of the turns ratio and the voltage ratio. This means, a transformer having less turns in the secondary than in the primary would step down the voltage, but would step up the current. Example: A transformer has a 6:1 voltage ratio. Find the current in the secondary if the current in the primary is 200 milliamperes.



Given:  $E_P = 6 \text{ V (assumed)}$   
 $E_S = 1 \text{ V}$   
 $I_P = 200 \text{ mA or } 0.2 \text{ A}$   
 $I_S = ?$

Solution:  $\frac{E_P}{E_S} = \frac{I_S}{I_P}$

Transposing for  $I_S$  :

$$I_S = \frac{E_P I_P}{E_S}$$

Substitution:

$$I_S = \frac{6 \text{ V} \times 0.2 \text{ A}}{1 \text{ V}}$$

$$I_S = 1.2 \text{ A}$$

The above example points out that although the voltage across the secondary is one-sixth the voltage across the primary, the current in the secondary is six times the current in the primary.

The above equations can be looked at from another point of view. The expression

$$\frac{N_P}{N_S}$$

is called the transformer **URNS RATIO** and may be expressed as a single factor. Remember, the turns ratio indicates the amount by which the transformer increases or decreases the voltage applied to the primary. For example, if the secondary of a transformer has two times as many turns as the primary, the voltage induced into the secondary will be two times the voltage across the primary. If the secondary has one-half as many turns as the primary, the voltage across the secondary will be one-half the voltage across the primary. However, the turns ratio and the current ratio of a transformer have an inverse relationship. Thus, a 1:2 step-up transformer will have one-half the current in the secondary as in the primary. A 2:1 step-down transformer will have twice the current in the secondary as in the primary.

Example: A transformer with a turns ratio of 1:12 has 3 amperes of current in the secondary. What is the value of current in the primary?

Given:  $N_P = 1 \text{ turn (assumed)}$   
 $N_S = 12 \text{ turns}$   
 $I_S = 3 \text{ A}$   
 $I_P = ?$

Solution:  $\frac{N_P}{N_S} = \frac{I_S}{I_P}$

Transposing for  $I_P$  :

$$I_P = \frac{N_S I_S}{N_P}$$

Substitution: 
$$I_P = \frac{12 \text{ turns} \times 3 \text{ A}}{1 \text{ turn}}$$
$$I_P = 36 \text{ A}$$

Q20. A transformer with a turns ratio of 1:3 has what current ratio?

Q21. A transformer has a turns ratio of 5:1 and a current of 5 amperes flowing in the secondary. What is the current flowing in the primary? (Assume no losses)

### POWER RELATIONSHIP BETWEEN PRIMARY AND SECONDARY WINDINGS

As just explained, the turns ratio of a transformer affects current as well as voltage. If voltage is doubled in the secondary, current is halved in the secondary. Conversely, if voltage is halved in the secondary, current is doubled in the secondary. In this manner, all the power delivered to the primary by the source is also delivered to the load by the secondary (minus whatever power is consumed by the transformer in the form of losses). Refer again to the transformer illustrated in figure 5-11. The turns ratio is 20:1. If the input to the primary is 0.1 ampere at 300 volts, the power in the primary is  $P = E \times I = 30$  watts. If the transformer has no losses, 30 watts is delivered to the secondary. The secondary steps down the voltage to 15 volts and steps up the current to 2 amperes. Thus, the power delivered to the load by the secondary is  $P = E \times I = 15 \text{ volts} \times 2 \text{ amps} = 30 \text{ watts}$ .

The reason for this is that when the number of turns in the secondary is decreased, the opposition to the flow of the current is also decreased. Hence, more current will flow in the secondary. If the turns ratio of the transformer is increased to 1:2, the number of turns on the secondary is twice the number of turns on the primary. This means the opposition to current is doubled. Thus, voltage is doubled, but current is halved due to the increased opposition to current in the secondary. The important thing to remember is that with the exception of the power consumed within the transformer, all power delivered to the primary by the source will be delivered to the load. The form of the power may change, but the power in the secondary almost equals the power in the primary.

As a formula:

$$P_S = P_P - P_L$$

Where:

$P_S$  = power delivered to the load by the secondary

$P_P$  = power delivered to the primary by the source

$P_L$  = power losses in the transformer

### TRANSFORMER LOSSES

Practical power transformers, although highly efficient, are not perfect devices. Small power transformers used in electrical equipment have an 80 to 90 percent efficiency range, while large, commercial powerline transformers may have efficiencies exceeding 98 percent.

The total power loss in a transformer is a combination of three types of losses. One loss is due to the dc resistance in the primary and secondary windings. This loss is called COPPER loss or  $I^2R$  loss. The two other losses are due to EDDY CURRENTS and to HYSTERESIS in the core of the transformer. Copper loss, eddy-current loss, and hysteresis loss result in undesirable conversion of electrical energy into heat energy.

*Q22. What is the mathematical relationship between the power in the primary ( $P_P$ ) and power in the secondary ( $P_S$ ) of a transformer?*

### **Copper Loss**

Whenever current flows in a conductor, power is dissipated in the resistance of the conductor in the form of heat. The amount of power dissipated by the conductor is directly proportional to the resistance of the wire, and to the square of the current through it. The greater the value of either resistance or current, the greater is the power dissipated. The primary and secondary windings of a transformer are usually made of low-resistance copper wire. The resistance of a given winding is a function of the diameter of the wire and its length. Copper loss can be minimized by using the proper diameter wire. Large diameter wire is required for high-current windings, whereas small diameter wire can be used for low-current windings.

### **Eddy-Current Loss**

The core of a transformer is usually constructed of some type of ferromagnetic material because it is a good conductor of magnetic lines of flux.

Whenever the primary of an iron-core transformer is energized by an alternating-current source, a fluctuating magnetic field is produced. This magnetic field cuts the conducting core material and induces a voltage into it. The induced voltage causes random currents to flow through the core which dissipates power in the form of heat. These undesirable currents are called EDDY CURRENTS.

To minimize the loss resulting from eddy currents, transformer cores are LAMINATED. Since the thin, insulated laminations do not provide an easy path for current, eddy-current losses are greatly reduced.

### **Hysteresis Loss**

When a magnetic field is passed through a core, the core material becomes magnetized. To become magnetized, the domains within the core must align themselves with the external field. If the direction of the field is reversed, the domains must turn so that their poles are aligned with the new direction of the external field.

Power transformers normally operate from either 60 Hz, or 400 Hz alternating current. Each tiny domain must realign itself twice during each cycle, or a total of 120 times a second when 60 Hz alternating current is used. The energy used to turn each domain is dissipated as heat within the iron core. This loss, called HYSTERESIS LOSS, can be thought of as resulting from molecular friction. Hysteresis loss can be held to a small value by proper choice of core materials.

## **TRANSFORMER EFFICIENCY**

To compute the efficiency of a transformer, the input power to and the output power from the transformer must be known. The input power is equal to the product of the voltage applied to the primary and the current in the primary. The output power is equal to the product of the voltage across the secondary and the current in the secondary. The difference between the input power and the output power

represents a power loss. You can calculate the percentage of efficiency of a transformer by using the standard efficiency formula shown below:

$$\text{Efficiency (in \%)} = \frac{P_{\text{out}}}{P_{\text{in}}} \times 100$$

Where:

$P_{\text{out}}$  = total output power delivered to the load

$P_{\text{in}}$  = total input power

Example. If the input power to a transformer is 650 watts and the output power is 610 watts, what is the efficiency?

Solution:

$$\text{Efficiency} = \frac{P_{\text{out}}}{P_{\text{in}}} \times 100$$

$$\text{Efficiency} = \frac{610 \text{ W}}{650 \text{ W}} \times 100$$

$$\text{Efficiency} = 93.8\%$$

Hence, the efficiency is approximately 93.8 percent, with approximately 40 watts being wasted due to heat losses.

*Q23. Name the three power losses in a transformer.*

*Q24. The input power to a transformer is 1,000 watts and the output power is 500 watts. What is the efficiency of the transformer, expressed as a percentage?*

## TRANSFORMER RATINGS

When a transformer is to be used in a circuit, more than just the turns ratio must be considered. The voltage, current, and power-handling capabilities of the primary and secondary windings must also be considered.

The maximum voltage that can safely be applied to any winding is determined by the type and thickness of the insulation used. When a better (and thicker) insulation is used between the windings, a higher maximum voltage can be applied to the windings.

The maximum current that can be carried by a transformer winding is determined by the diameter of the wire used for the winding. If current is excessive in a winding, a higher than ordinary amount of power will be dissipated by the winding in the form of heat. This heat may be sufficiently high to cause the insulation around the wire to break down. If this happens, the transformer may be permanently damaged.

The power-handling capacity of a transformer is dependent upon its ability to dissipate heat. If the heat can safely be removed, the power-handling capacity of the transformer can be increased. This is

sometimes accomplished by immersing the transformer in oil, or by the use of cooling fins. The power-handling capacity of a transformer is measured in either the volt-ampere unit or the watt unit.

Two common power generator frequencies (60 hertz and 400 hertz) have been mentioned, but the effect of varying frequency has not been discussed. If the frequency applied to a transformer is increased, the inductive reactance of the windings is increased, causing a greater ac voltage drop across the windings and a lesser voltage drop across the load. However, an increase in the frequency applied to a transformer should not damage it. But, if the frequency applied to the transformer is decreased, the reactance of the windings is decreased and the current through the transformer winding is increased. If the decrease in frequency is enough, the resulting increase in current will damage the transformer. For this reason a transformer may be used at frequencies above its normal operating frequency, but not below that frequency.

*Q25. Why should a transformer designed for 400 hertz operation not be used for 60 hertz operation?*

## **TYPES AND APPLICATIONS OF TRANSFORMERS**

The transformer has many useful applications in an electrical circuit. A brief discussion of some of these applications will help you recognize the importance of the transformer in electricity and electronics.

### **POWER TRANSFORMERS**

Power transformers are used to supply voltages to the various circuits in electrical equipment. These transformers have two or more windings wound on a laminated iron core. The number of windings and the turns per winding depend upon the voltages that the transformer is to supply. Their coefficient of coupling is 0.95 or more.

You can usually distinguish between the high-voltage and low-voltage windings in a power transformer by measuring the resistance. The low-voltage winding usually carries the higher current and therefore has the larger diameter wire. This means that its resistance is less than the resistance of the high-voltage winding, which normally carries less current and therefore may be constructed of smaller diameter wire.

So far you have learned about transformers that have but one secondary winding. The typical power transformer has several secondary windings, each providing a different voltage. The schematic symbol for a typical power-supply transformer is shown in figure 5-12. For any given voltage across the primary, the voltage across each of the secondary windings is determined by the number of turns in each secondary. A winding may be center-tapped like the secondary 350 volt winding shown in the figure. To center tap a winding means to connect a wire to the center of the coil, so that between this center tap and either terminal of the winding there appears one-half of the voltage developed across the entire winding. Most power transformers have colored leads so that it is easy to distinguish between the various windings to which they are connected. Carefully examine the figure which also illustrates the color code for a typical power transformer. Usually, red is used to indicate the high-voltage leads, but it is possible for a manufacturer to use some other color(s).

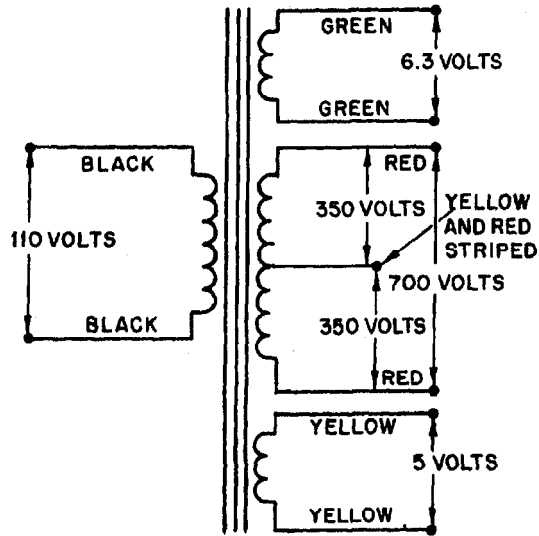

Figure 5-12.—Schematic diagram of a typical power transformer.

There are many types of power transformers. They range in size from the huge transformers weighing several tons—used in power substations of commercial power companies—to very small ones weighing as little as a few ounces—used in electronic equipment.

### AUTOTRANSFORMERS

It is not necessary in a transformer for the primary and secondary to be separate and distinct windings. Figure 5-13 is a schematic diagram of what is known as an AUTOTRANSFORMER. Note that a single coil of wire is "tapped" to produce what is electrically a primary and secondary winding. The voltage across the secondary winding has the same relationship to the voltage across the primary that it would have if they were two distinct windings. The movable tap in the secondary is used to select a value of output voltage, either higher or lower than  $E_p$ , within the range of the transformer. That is, when the tap is at point A,  $E_s$  is less than  $E_p$ ; when the tap is at point B,  $E_s$  is greater than  $E_p$ .

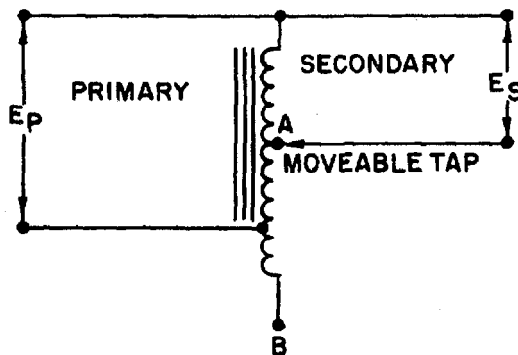

Figure 5-13.—Schematic diagram of an autotransformer.

## AUDIO-FREQUENCY TRANSFORMERS

Audio-frequency (af) transformers are used in af circuits as coupling devices. Audio-frequency transformers are designed to operate at frequencies in the audio frequency spectrum (generally considered to be 15 Hz to 20kHz). They consist of a primary and a secondary winding wound on a laminated iron or steel core. Because these transformers are subjected to higher frequencies than are power transformers, special grades of steel such as silicon steel or special alloys of iron that have a very low hysteresis loss must be used for core material. These transformers usually have a greater number of turns in the secondary than in the primary; common step-up ratios being 1 to 2 or 1 to 4. With audio transformers the impedance of the primary and secondary windings is as important as the ratio of turns, since the transformer selected should have its impedance match the circuits to which it is connected.

## RADIO-FREQUENCY TRANSFORMERS

Radio-frequency (rf) transformers are used to couple circuits to which frequencies above 20,000 Hz are applied. The windings are wound on a tube of nonmagnetic material, have a special powdered-iron core, or contain only air as the core material. In standard broadcast radio receivers, they operate in a frequency range of from 530 kHz to 1550 kHz. In a short-wave receiver, rf transformers are subjected to frequencies up to about 20 MHz - in radar, up to and even above 200 MHz.

## IMPEDANCE-MATCHING TRANSFORMERS

For maximum or optimum transfer of power between two circuits, it is necessary for the impedance of one circuit to be matched to that of the other circuit. One common impedance-matching device is the transformer. To obtain proper matching, you must use a transformer having the correct turns ratio. The number of turns on the primary and secondary windings and the impedance of the transformer have the following mathematical relationship:

$$\frac{N_P}{N_S} = \sqrt{\frac{Z_P}{Z_S}}$$

Because of this ability to match impedances, the impedance-matching transformer is widely used in electronic equipment.

*Q26. List five different types of transformers according to their applications.*

*Q27. The leads to the primary and to the high-voltage secondary windings of a power transformer usually are of what color?*

## SAFETY

### EFFECTS OF CURRENT ON THE BODY

Before learning safety precautions, you should look at some of the possible effects of electrical current on the human body. The following table lists some of the probable effects of electrical current on the human body.

<u>AC 60 Hz (mA)</u>	<u>DC (mA)</u>	<u>Effects</u>
0-1	0-4	Perception
1-4	4-15	Surprise
4-21	15-80	Reflex action
21-40	80-160	Muscular inhibition
40-100	160-300	Respiratory failure
Over 100	Over 300	Usually fatal

Note in the above chart that a current as low as 4 mA can be expected to cause a reflex action in the victim, usually causing the victim to jump away from the wire or other component supplying the current. While the current should produce nothing more than a tingle of the skin, the quick action of trying to get away from the source of this irritation could produce other effects (such as broken limbs or even death if a severe enough blow was received at a vital spot by the shock victim).

It is important for you to recognize that the resistance of the human body cannot be relied upon to prevent a fatal shock from a voltage as low as 115 volts or even less. Fatalities caused by human contact with 30 volts have been recorded. Tests have shown that body resistance under unfavorable conditions may be as low as 300 ohms, and possibly as low as 100 ohms (from temple to temple) if the skin is broken. Generally direct current is not considered as dangerous as an equal value of alternating current. This is evidenced by the fact that reasonably safe "let-go currents" for 60 hertz, alternating current, are 9.0 milliamperes for men and 6.0 milliamperes for women, while the corresponding values for direct current are 62.0 milliamperes for men and 41.0 milliamperes for women. Remember, the above table is a list of probable effects. The actual severity of effects will depend on such things as the physical condition of the work area, the physiological condition and resistance of the body, and the area of the body through which the current flows. Thus, based on the above information, you MUST consider every voltage as being dangerous.

## **ELECTRIC SHOCK**

Electric shock is a jarring, shaking sensation you receive from contact with electricity. You usually feel like you have received a sudden blow. If the voltage and resulting current are sufficiently high, you may become unconscious. Severe burns may appear on your skin at the place of contact; muscular spasms may occur, perhaps causing you to clasp the apparatus or wire which caused the shock and be unable to turn it loose.

## **RESCUE AND CARE OF SHOCK VICTIMS**

The following procedures are recommended for rescue and care of electric shock victims:

1. Remove the victim from electrical contact at once, but **DO NOT** endanger yourself. You can do this by:
  - Throwing the switch if it is nearby
  - Cutting the cable or wires to the apparatus, using an ax with a wooden handle while taking care to protect your eyes from the flash when the wires are severed



- Using a dry stick, rope, belt, coat, blanket, shirt or any other nonconductor of electricity, to drag or push the victim to safety
2. Determine whether the victim is breathing. If the victim is not breathing, you must apply artificial ventilation (respiration) without delay, even though the victim may appear to be lifeless. **DO NOT STOP ARTIFICIAL RESPIRATION UNTIL MEDICAL AUTHORITY PRONOUNCES THE VICTIM DEAD.**
  3. Lay the victim face up. The feet should be about 12 inches higher than the head. Chest or head injuries require the head to be slightly elevated. If there is vomiting or if facial injuries have occurred which cause bleeding into the throat, the victim should be placed on the stomach with the head turned to one side and 6 to 12 inches lower than the feet.
  4. Keep the victim warm. The injured person's body heat must be conserved. Keep the victim covered with one or more blankets, depending on the weather and the person's exposure to the elements. Artificial means of warming, such as hot water bottles should not be used.
  5. Drugs, food, and liquids should not be administered if medical attention will be available within a short time. If necessary, liquids may be administered. Small amounts of warm salt water, tea or coffee should be used. Alcohol, opiates, and other depressant substances must never be administered.
  6. Send for medical personnel (a doctor if available) at once, but do **NOT** under any circumstances leave the victim until medical help arrives.

For complete coverage of administering artificial respiration, and on treatment of burn and shock victims, refer to *Standard First Aid Training Course*, NAVEDTRA 10081 (Series).

### **SAFETY PRECAUTIONS FOR PREVENTING ELECTRIC SHOCK**

You must observe the following safety precautions when working on electrical equipment:

1. Never work alone. Another person may save your life if you receive an electric shock.
2. Work on energized circuits **ONLY WHEN ABSOLUTELY NECESSARY**. Power should be tagged out, using approved tagout procedures, at the nearest source of electricity.
3. Stand on an approved insulating material, such as a rubber mat.
4. Discharge power capacitors before working on deenergized equipment. Remember, a capacitor is an electrical power storage device.
5. When you must work on an energized circuit, wear rubber gloves and cover as much of your body as practical with an insulating material (such as shirt sleeves). This is especially important when you are working in a warm space where sweating may occur.
6. Deenergize equipment prior to hooking up or removing test equipment.
7. Work with only one hand inside the equipment. Keep the other hand clear of all obstacles that may provide a path, such as a ground, for current to flow.
8. Wear safety goggles. Sparks could damage your eyes, as could the cooling liquids in some components such as transformers should they overheat and explode.

9. Keep a cool head and think about the possible consequences before performing any action. Carelessness is the cause of most accidents. Remember the best technician is NOT necessarily the fastest one, but the one who will be on the job tomorrow.

Q28. What is the cause of most accidents?

Q29. Before working on electrical equipment containing capacitors, what should you do to the capacitors?

Q30. When working on electrical equipment, why should you use only one hand?

## SUMMARY

As a study aid and for future reference, the important points of this chapter have been summarized below.

**BASIC TRANSFORMER**—The basic transformer is an electrical device that transfers alternating-current energy from one circuit to another circuit by magnetic coupling of the primary and secondary windings of the transformer. This is accomplished through mutual inductance ( $M$ ). The coefficient of coupling ( $K$ ) of a transformer is dependent upon the size and shape of the coils, their relative positions, and the characteristic of the core between the two coils. An ideal transformer is one where all the magnetic lines of flux produced by the primary cut the entire secondary. The higher the  $K$  of the transformer, the higher is the transfer of the energy. The voltage applied to the primary winding causes current to flow in the primary. This current generates a magnetic field, generating a counter emf (cemf) which has the opposite phase to that of the applied voltage. The magnetic field generated by the current in the primary also cuts the secondary winding and induces a voltage in this winding.

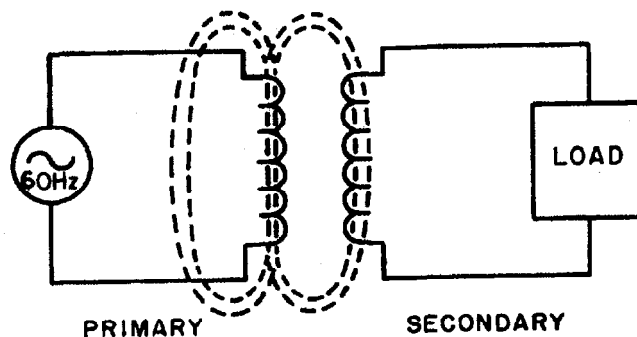

**TRANSFORMER CONSTRUCTION**—A TRANSFORMER consists of two coils of insulated wire wound on a core. The primary winding is usually wound onto a form, then wrapped with an insulating material such as paper or cloth. The secondary winding is then wound on top of the primary and both windings are wrapped with insulating material. The windings are then fitted onto the core of the transformer. Cores come in various shapes and materials. The most common materials are air, soft iron, and laminated steel. The most common types of transformers are the shell-core and the hollow-core types. The type and shape of the core is dependent on the intended use of the transformer and the voltage applied to the current in the primary winding.

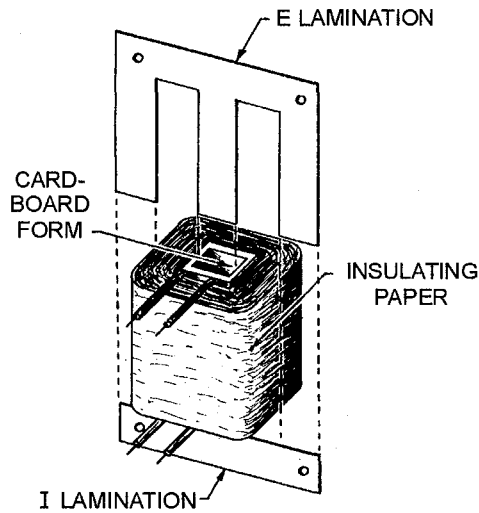

**EXCITING CURRENT**—When voltage is applied to the primary of a transformer, exciting current flows in the primary. The current causes a magnetic field to be set up around both the primary and the secondary windings. The moving flux causes a voltage to be induced into the secondary winding, countering the effects of the counter emf in the primary.

**PHASE**—When the secondary winding is connected to a load, causing current to flow in the secondary, the magnetic field decreases momentarily. The primary then draws more current, restoring the magnetic field to almost its original magnitude. The phase of the current flowing in the secondary circuit is dependent upon the phase of the voltage impressed across the primary and the direction of the winding of the secondary. If the secondary were wound in the same direction as the primary, the phase would be the same. If wound opposite to the primary, the phase would be reversed. This is shown on a schematic drawing by the use of phasing dots. The dots mean that the leads of the primary and secondary have the same phase. The lack of phasing dots on a schematic means a phase reversal.

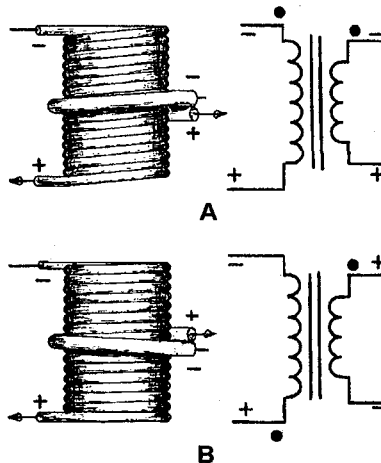

**TURNS RATIO**—The **TURNS RATIO** of a transformer is the ratio of the number of turns of wire in the primary winding to the number of turns in the secondary winding. When the turns ratio is stated, the number representing turns on the primary is always stated first. For example, a 1:2 turns ratio means

the secondary has twice the number of turns as the primary. In this example, the voltage across the secondary is two times the voltage applied to the primary.

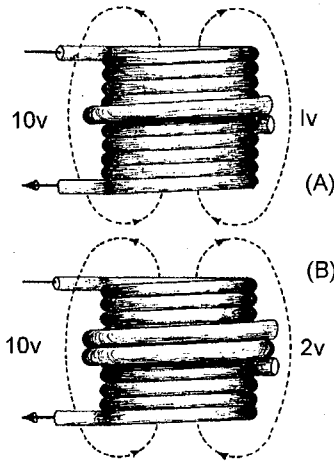

**POWER AND CURRENT RATIOS**—The power and current ratios of a transformer are dependent on the fact that power delivered to the secondary is always equal to the power delivered to the primary minus the losses of the transformer. This will always be true, regardless of the number of secondary windings. Using the law of power and current, it can be stated that current through the transformer is the inverse of the voltage or turns ratio, with power remaining the same or less, regardless of the number of secondaries.

**TRANSFORMER LOSSES**—Transformer losses have two sources—copper loss and magnetic loss. Copper losses are caused by the resistance of the wire ( $I^2R$ ). Magnetic losses are caused by eddy currents and hysteresis in the core. Copper loss is a constant after the coil has been wound and therefore a measurable loss. Hysteresis loss is constant for a particular voltage and current. Eddy-current loss, however, is different for each frequency passed through the transformer.

**TRANSFORMER EFFICIENCY**—The amplitude of the voltage induced in the secondary is dependent upon the efficiency of the transformer and the turns ratio. The efficiency of a transformer is related to the power losses in the windings and core of the transformer. Efficiency (in percent) equals  $P_{out}/P_{in} \times 100$ . A perfect transformer would have an efficiency of 1.0 or 100%.

**POWER TRANSFORMER**—A transformer with two or more windings wound on a laminated iron core. The transformer is used to supply stepped up and stepped down values of voltage to the various circuits in electrical equipment.

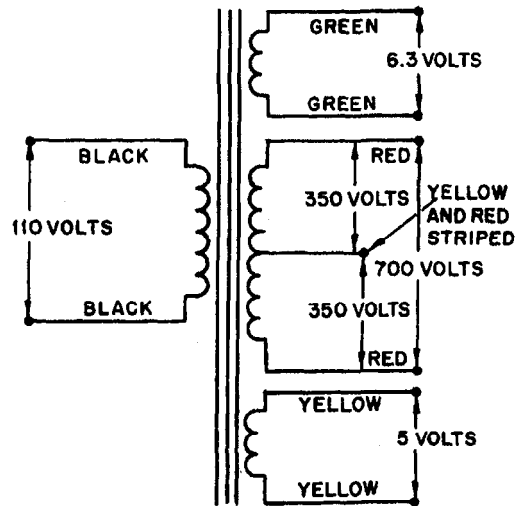

**AUTOTRANSFORMER**—A transformer with a single winding in which the entire winding can be used as the primary and part of the winding as the secondary, or part of the winding can be used as the primary and the entire winding can be used as the secondary.

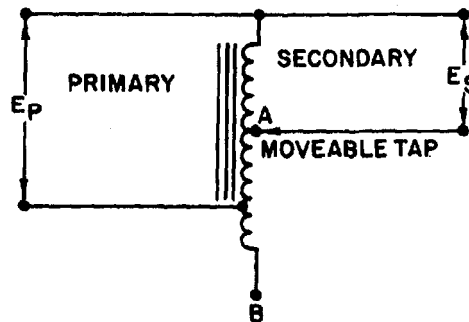

**AUDIO-FREQUENCY TRANSFORMER**—A transformer used in audio-frequency circuits to transfer af signals from one circuit to another.

**RADIO-FREQUENCY TRANSFORMER**—A transformer used in a radio-frequency circuit to transfer rf signals from one circuit to another.

**IMPEDANCE-MATCHING TRANSFORMER**—A transformer used to match the impedance of the source and the impedance of the load. The mathematical relationship of the turns and impedance of the transformer is expressed by the equation:

$$\frac{N_P}{N_S} = \sqrt{\frac{Z_P}{Z_S}}$$

### ANSWERS TO QUESTIONS Q1. THROUGH Q30.

- A1. *The transfer of energy from one circuit to another circuit by electromagnetic induction.*
- A2. *Primary winding; secondary winding; core.*
- A3. *Air; soft iron; steel.*
- A4. *Hollow-core type; shell-core type.*
- A5. *Primary to source; secondary to load.*
- A6. *Additional insulation is provided between the layers of windings in the high-voltage transformer.*
- A7.
- a. *air-core transformer*
  - b. *iron-core transformer*
  - c. *iron-core center tapped transformer*
- A8. *A voltage is applied to the primary, but no load is connected to the secondary.*
- A9. *Exciting current is the current that flows in the primary of a transformer with the secondary open (no load attached).*
- A10. *Self-induced or counter emf.*
- A11. *The magnetic lines generated by the current in the primary cut the secondary windings and induce a voltage into them.*
- A12. *In phase. Remember, the cemf of the primary is 180 degrees out of phase with the applied voltage. The induced voltage of the secondary of an unlike-wound transformer is also 180 degrees out of phase with the primary voltage.*
- A13.

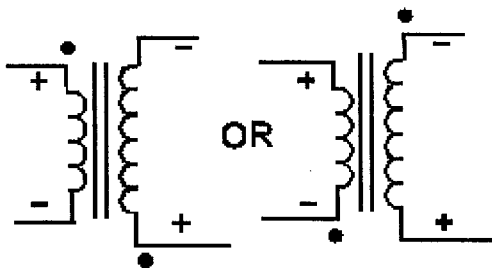

Note: Remember the dots indicate areas of like polarity, NOT a particular polarity.

- A14. *Lines of flux generated by one winding which do not link the other winding.*
- A15. *It causes K to be less than unity (1).*
- A16. *Step up.*

A17.

$$\frac{E_S}{E_P} = \frac{N_S}{N_P} \text{ or}$$
$$E_S = \frac{E_P N_S}{N_P} = \frac{45 \text{ V} \times 1500 \text{ turns}}{500 \text{ turns}} = 135 \text{ V}$$

A18.

$$\frac{E_P}{E_S} = \frac{N_P}{N_S} \text{ or}$$
$$E_P = \frac{N_P E_S}{N_S} = \frac{7 \text{ turns} \times 5 \text{ V}}{1 \text{ turn}} = 35 \text{ V}$$

A19.

$$\frac{E_P}{E_S} = \frac{N_P}{N_S} \text{ or}$$
$$N_S = \frac{E_S N_P}{E_P} = \frac{420 \text{ V} \times 800 \text{ turns}}{60 \text{ V}} = 5600 \text{ turns}$$

A20.

$$\frac{N_P}{N_S} = \frac{I_S}{I_P} = \frac{1}{3} = 3 : 1 \text{ current ratio}$$

(Turns ratio and current ratio have an inverse relationship.)

A21.

$$\frac{N_P}{N_S} = \frac{I_S}{I_P} \text{ or}$$
$$I_P = \frac{N_S I_S}{N_P} = \frac{1 \text{ turn} \times 5 \text{ A}}{5 \text{ turns}} = 1 \text{ A}$$

A22.

$$P_S = P_P - P_L$$

A23. *Copper loss, eddy-current loss, and hysteresis loss.*

A24.

$$\text{Eff (in \%)} = \frac{P_{\text{out}}}{P_{\text{in}}} \times 100 = \frac{500 \text{ W}}{1000 \text{ W}} \times 100 = 0.5 \times 100 = 50 \%$$

A25. *The inductive reactance at 60 hertz would be too low. The resulting excessive current would probably damage the transformer.*

A26.

- a. *Power transformer*
- b. *Autotransformer*
- c. *Impedance-matching transformer*
- d. *Audio-frequency transformer*
- e. *Radio-frequency transformer*

A27. *Primary leads-black; secondary leads-red.*

A28. *Carelessness.*

A29. *Discharge them by shorting them to ground.*

A30. *To minimize the possibility of providing a path for current through your body.*